



GARANTIA DE RESPALDO

MANUAL USUARIO

MVV2-16 MOTOR DIESEL 4T BICILINDRICO

16 HP @ 3000RPM

26/04/2018



CONTENTS

1. FOR YOUR SAFETY	(1)
1.1 Warning Symbols	(1)
1.2 Safety Precautions	(2)
2. PRODUCT OVERVIEW	(5)
2.1 Drive System and Applications	(5)
2.2 Specifications	(7)
2.3 External Views	(8)
2.4 Functions of Major Parts	(9)
2.5 Operation system	(10)
3. BEFORE OPERATION	(11)
3.1 Preparation of Fuel Oil , Lube Oil & Cooling Water	(11)
3.2 Supplying the Fuel Oil	(13)
3.3 Supplying the Lube Oil	(15)
3.4 Supplying the Cooling Water	(15)
3.5 Cranking (No-load)	(16)
3.6 Checking the Lube oil and cooling Water	(17)
4. OPERATION	(17)
4.1 Check Before Daily Operation	(18)
4.2 Starting	(20)
4.3 Adjusting the Speed	(22)
4.4 Precautions During Operation	(22)
4.5 Stopping the Engine	(23)
4.6 Taking Care During Long-term Storage	(24)
5. MAINTENANCE	(25)
5.1 Checking	(25)
5.2 Periodic Check Program	(27)
5.3 Periodic Check Procedure	(29)
6. TROUBLESHOOTING	(37)

1.FOR YOUR SAFETY

Safety precautions and notices are described throughout this operation manual for safe operation. Symbols used in this manual and their meanings are explained below.

1.1 Warning Symbols

Following the precautions described in this manual will enable you to use this engine with complete satisfaction. Failure to observe any of the rules and precautions, however, may result in a scalding, injury, fire or engine damage.

Read this manual carefully and be sure you fully understand it before beginning operation.

- These are the warning signs which are used in this manual and the products.



Indicates an imminently hazardous situation which, if not avoided, WILL result in death or serious injury.



Indicates a potentially hazardous situation which, if not avoided, COULD result in death or serious injury.



Indicates a potentially hazardous situation which, if not avoided, MAY result in minor or moderate injury.

- The descriptions captioned by [NOTICE] are particularly important cautions for handling. If you ignore them, the performance of your machine may be deteriorated, leading to trouble.

Make sure to also observe warnings indicated on the driven machine and instructions contained in the operation manual supplied from the driven machine manufacturer



1.2 Safety Precautions

Observe these instructions for your own safety.

Precautions for Operation

Burns from Scalding

- Never open the radiator filler cap while the engine is hot. Steam and hot water will spurt out and seriously burn you. Wait until the radiator is cooled down after the engine has stopped, wrap the filler cap with a rag piece and slowly open the cap.
- Securely tighten the filler cap after checking the radiator. Steam can spurt out during operation, if the cap is tightened loose.

Proper Ventilation of the Battery Area

- Keep the area around the battery well ventilated, paying attention to keep away any fire source. During operation or charging, hydrogen gas is generated from the battery and can be easily ignited.

Fires from Oil Ignition

- Be sure to use the proper diesel fuel. Filling with gasoline or the like by mistake will result in ignition.
- Be sure to stop the engine before refueling.
- If you spill fuel, wipe off such spillage completely.
- Never place oils or other flammable materials close to engine, as this could result in ignition.

Exhaust Gas Poisoning

- Never block up windows, ventilation ports, or other ventilation equipment such as ventilators of the engine room. Ensure good ventilation during engine operation. Inhaling the exhaust gas is harmful.
- Never operate the engine in a closed room, tunnel, underground room, manhole, or ship's hold. It is dangerous since exhaust gas cannot get out.



Keep Away from Moving Parts

- Pay sufficient attention so as not to touch rotating parts, or bring your hands or part of your body or clothes close to rotating parts while the engine is operating. Otherwise, you may get injured by being caught by the cooling fan, flywheel or PTO shaft. Never operate the engine without covers on the rotating parts.
- Check before starting the engine to see that any tools or clothes used in the maintenance remains around the engine.



NOTICE

Scalds from Contact with Hot Engine Parts

- Pay sufficient attention not to bring part of your hand and body or clothes in contact with the silencer, exhaust pipe and engine body during operation or immediately after stopping the engine.
- The whole engine is hot may cause scalding.



NOTICE

Never Operate the Engine while you are under the Influence of alcohol

- Also, never operate the engine when you are ill or feel unwell as this results in unexpected accidents.

Safety Precautions for Inspection

Do not come in contact with battery electrolyte.

- Pay sufficient attention to avoid your eyes or skin from being in contact with the fluid. The battery electrolyte is dilute sulfuric acid and causes burns. Wash it off immediately with a large amount of fresh water if you get any on you.

Fire due to Electric Short-Circuits

- Make sure to turn off the battery switch or disconnect the negative cable (—) before inspecting the electrical system. Failure to do so could cause shortcircuiting and fires.



Keep off Rotating Parts

- Stop the engine before starting service operation. If you must inspect while the engine is operating, never bring your hand, body or clothing in contact with or close to rotating parts, as you may get injured by being caught by rotating parts.

Precautions to Prevent Scalds When Draining Hot Oil and Water

- If lube oil must be drained from the engine while it is still hot, take care not to let the oil splash on you to avoid scalding.
- Wait until the temperature goes down before draining the coolant. Hot water may splash to burn you.

Beware of dirt from air blowing

- Wear protective equipment such as goggles to protect your eyes when blowing compressed air. Dust or flying debris can hurt eyes.

Modification not authorized

- Never modify this product or release the limit devices (which limit engine speed, fuel injection quantity, etc.).
- Such modification or release will impair the safety and performance of the product and functions and result in shorter engine life.

Disposal of waste materials

- Put waste oil or drainage in a container. Never dispose of waste oil or drainage to the outdoors, into a sewer, river, or the sea.
- Dispose of waste materials safely observing relevant regulations and laws. Ask a specialized waste recovery company for collection and disposal



2. PRODUCT OVERVIEW

2.1 Drive System and Applications

This product is a vertical water-cooled small type multi-purpose diesel engine.

- The power is transmitted downward from the engine to make the driven machine structure simple. Since the engine requires a small mounting area, compact driven machine can be designed.
- Powerful and long-lasting torque characteristics are available for efficiency improvement.
- The engine is economical as it consumes extremely little fuel and lube oil.
- The durability and reliability are increased by the forced water cooling (radiator) and forced lubrication system.
- The combustion performance is high and the engine is clean with little toxic exhaust constituents. It is ecology oriented with significantly less vibration and noise.
- The structure facilitates operation and maintenance.

We are sure that you will be satisfied with the above feature.

The main engine specifications are standardized for multi-purpose application. Options (fuel tank, remote controller, instruments, alarms, etc.) are provided to meet various operating conditions.

Since installation and fitting of the engine require special knowledge and skill, always consult with your dealer or CHANGCHAI distributor.



- To obtain the maximum engine performance with a minimum risk of machine troubles and accidents, it is very important to match the engine with the driven machine.
- Carefully establish safe exhaust piping, electric wiring, ventilation and accurate engine installation.
- Certain applications may require an inspection by the authorities.

This manual describes operation based on the standard specifications. When coupled with the driven machine, operation procedures for options and accessories may vary depending on the structure of that driven machine.

For optional parts or accessories, refer to the operation manual provided by the driven machine manufacturer and observe the instructions and cautions given therein.



2.2 Specifications

Model		MVV2-16	
Type		Vertical in-line, 2-cylinder, water cooled, 4-stroke diesel engine	
Number of cylinders – bore x stroke	mm	2-80x79	
Displacement	L	0.794	
Aspiration		Natural aspiration	
Rated output (Gross)	rpm	3000	3600
	kW	12	14
	PS	16.3	19
Combustion system		Swirl pre combustion chamber system	
Starting system		Starting motor	
Cooling system		Radiator	
Lubricating system		Forced lubrication with trochoid pump	
Power take-off position		Lower position of vertical PTO shaft (opposite to flywheel)	
Direction of PTO rotation		Counterclockwise as viewed from opposite of the flywheel	
Starting motor capacity		12V, 1.4KW	
Alternator capacity		12V 20A	
Recommended battery capacity		12V-36Ah(55Ah) or larger	
Lube oil capacity	L	2.3(oil pan)	
Cooling water capacity	L	Engine: 2.6, Sub-tank: 0.3	
Engine dimensions	mm	616x486x528	
Engine weight(dry)	kg	57.5	

2.3 External Views

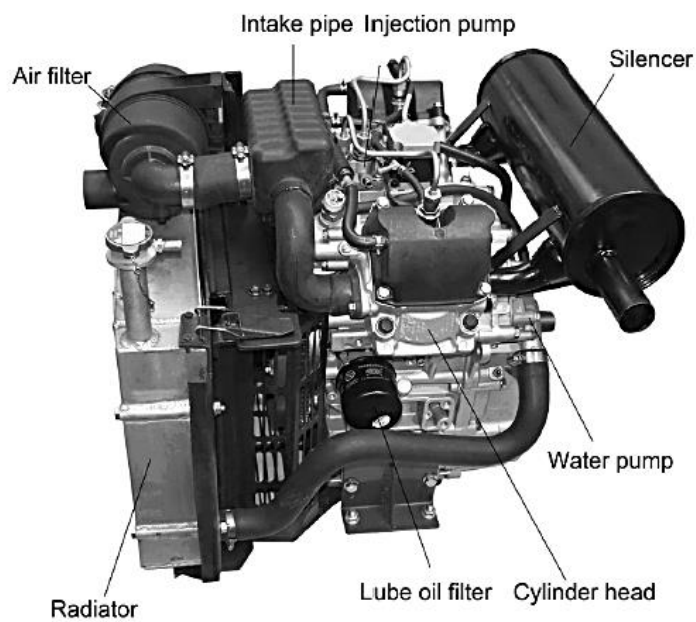
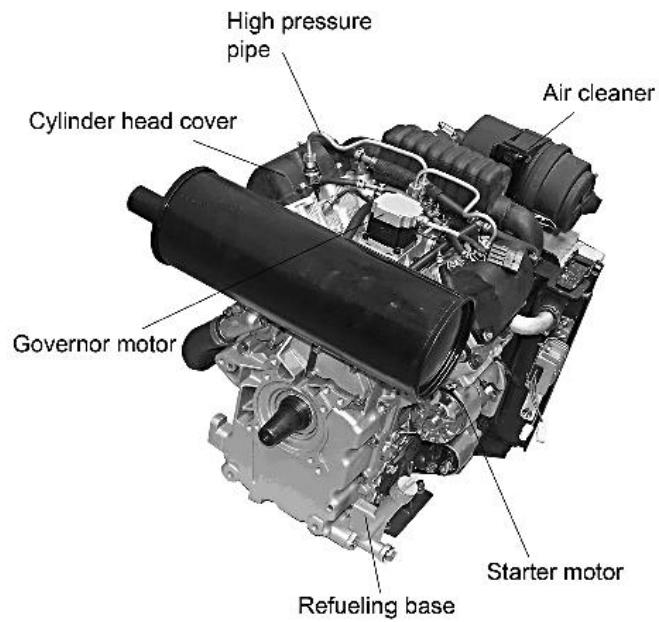

2.4 Functions of Major Parts

Parts	Functions
Fuel filter	Removes dirt and water from the fuel oil. Periodic replacement of filter paper element is necessary before it is clogged with dirt. Replace the whole cartridge assembly for renewal.
Fuel feed pump	Stand-alone type, electromagnetic pump to feed fuel to the fuel injection pump.
Lube oil filler port	Lube oil filler port of which cap has the oil level gauge(dipstick).
Lube oil filter	Removes fine metal debris and carbon in the lube oil. Periodic replacement of filter paper element is necessary before it is clogged. Replace it by cartridge assembly.
Air cleaner	Air intake port where drifting dust is prevented from entering the chamber by means of the internal element, and it also serves to suppress the air intake noise. Periodic inspection (cleaning or replacement) of the filter paper element is necessary before it is clogged with dust.
[Cooling water system] Radiator Cooling fan and cooling water pump Radiator cap	This engine is water-cooled system by means of radiator. Serves as cooling water storage tank and heat exchanger. The cooling fan under the radiator is driven by the crankshaft end to cool the water down. The cooling water pump under the engine circulates the cool them, and returns the water into the radiator. The radiator cap is equipped with pressure regulating valves: the release and vacuum valves. When the cooling water temperature rises, the radiator inner pressure gets higher and the release valve opens to release steam and overflowing thermally expanded hot water into the sub-tank through a rubber hose.
Starting motor	DC motor for electrical starting. When the power is turned on, the pinion gear engages with the ring gear of flywheel to start the engine.
Alternator	DC generator to charge the battery while the engine is in operation. It is installed on the crankshaft and located under the flywheel.

2.5 Operation System

Operation system described here includes the devices for starting, stopping, and monitoring the performance.

(1) Starting switch

This is a 3-stage rotary switch.

Position is changed by turning the key inserted to the slot.

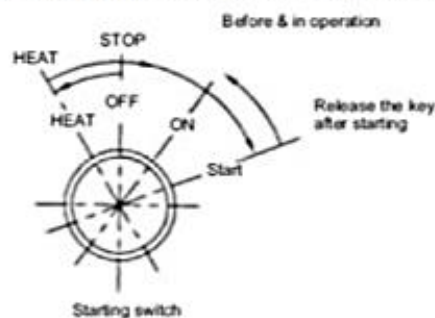

OFF: This is the engine stop position, and all electric current is cut off. The key can be inserted and removed at this position.

ON: This position provides the normal operating condition. Current flows to instruments and alarm devices.

START: This is the starting position. The self-starting motor rotates to crank the engine. The key returns automatically to the ON when it is released.

HEAT: This position is used to energize the glow plug. The key returns automatically to the OFF when it is released.

(2) Glow plug cold starting aid

Located on the cylinder head, this device preheats the combustion chamber for easy starting at low temperatures. The glow plug is energized while the starting switch is at the HEAT position. When using the glow plug, keep the starting switch at HEAT for approx. 15 seconds and then turn it to the START to start the engine.

(3) Engine stopping device

When the starting switch is turned to OFF, the governor pulls the valve of fuel injection pump to stop fuel injection so as to stop the engine.

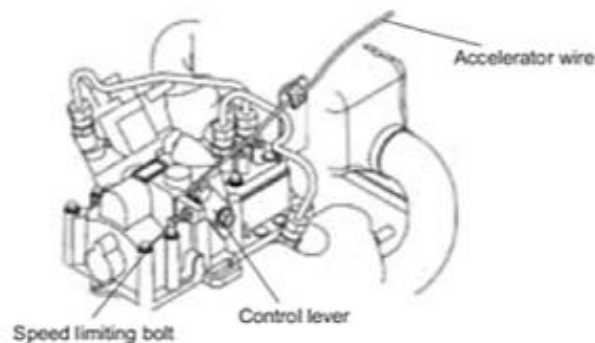

(4) Alarm lamp

These lamps notify abnormal states during the engine operation.

Charge warning lamp The lamp is off while the battery is recharged. It goes on when the battery is not charged normally.

Lube oil pressure warning lamp This lamp comes on if an abnormally low lube oil pressure 4.9 kPa (0.5kgf/cm²) or below is detected by the pressure sensor.

Water temperature warning lamp This lamp lights when the cooling water temperature rises above 110°C .

(5) Accelerator lever

Switch between high speed and low speed by operating the accelerator lever.

3. BEFORE OPERATION

Follow procedures in 3.1 through 3.6 for preparation before starting the engine.

3.1 Preparation of Fuel Oil, Lube Oil & Cooling Water

3.1.1 Fuel oil

(1) Fuel oil selection

[Diesel fuel standard for various countries]

ISO 8217 DMA

ASTMD 975 Grade No.1-D or No.2-D

GB/T252-1994 light diesel fuel Grade No. 0 is used in summer, and grade No. -10 , -20 , -30 is used in winter.

Diesel fuel is classified in terms of the pour point. Certain grade of oil may have poor fluidity at low temperatures. Select the proper oil according to the ambient temperature.



Type of Diesel fuel recommended		
Ambient temperature	GB/T 252	ASTM D975
-5 or above	-10#	Grade 2-D
-15 or above	-20#	Grade 1-D
-25 or above	-30#	

⚠ NOTICE Use of fuel oil other than the specified type may fail to obtain the intended engine performance and cause component trouble.

(2) Handling the fuel oil

- Use a clean vessel to stow oil.
- Keep the oil in a place clear of rain or dust
Mixture of water or dust causes engine troubles.
- Stand the fuel oil in the vessel for several hours until the water or dust settles down on the bottom.

Use only clean upper oil by pumping it up

3.1.2 Lube oil

⚠ NOTICE Use of other than the specified lube oil may cause inner parts seizure or early wear, leading to shorten the engine service life.

(1) Applicable lube oil

Be sure to select grade CD or CF (API classification)

Select the viscosity number according to the ambient temperature by referring

below:

SAE30# 20 (in summer)

SAE20# 10 ~20 (in spring, autumn)

SAE10W30 -5~ 20 (in winter)

SAE5W20 -20 ~30 (in winter)

(2) Handling of lube oil

- Carefully store and handle the oil so as to prevent dust or dirt entrance. When supplying the oil, pay attention and clean around the filler port.
- Do not mix different types of oil as it may adversely affect the lubricating performance.

3.1.3 Cooling water

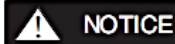
**NOTICE**

Incorrect use of cooling water may cause the water scale of water pocket in the radiator, cylinder block and cylinder head. It will adversely affect the heat release.

Freezing cooling water may split the radiator, cylinder block and cylinder head.

(1) Cooling water

Use clean soft water (Tap water, rainwater) and be sure to add the long life coolant in order to prevent rust buildup and freezing.

(2) Long life coolant

Select a good-quality long life coolant for car use.

(3) Mixing ratio of cooling water and Long Life Coolant (LLC)

Determine the mixing ratio of the cooling water and LLC in accordance with the manufacturer's instructions.

If the mixing ration of LLC is too small, the rust preventive effect will diminish. On the contrary, and excessive amount of LLC will adversely affect the cooling performance of engine. Be sure to follow the mixing ratio specified by the manufacturer.

3.2 Supplying the Fuel Oil

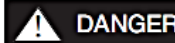
**DANGER**

from oil ignition

- be sure to use the correct type of fuel when refueling. Filling of gasoline or the like by mistake may cause ignition.
- be sure to stop the engine before refueling.
- if spilt, wipe such spillage carefully.
- Never place oil or other flammable material near engine as this could result in ignition.

3.2.1 Filling up the fuel tank

1. Fill the fuel tank with clean fuel oil not contaminated with dust or water. The tank should be filled to approx. 90% of the full capacity. Be careful not to spill it during operation.

2. Bleeding air from the fuel system to maintain the normal supply of fuel.

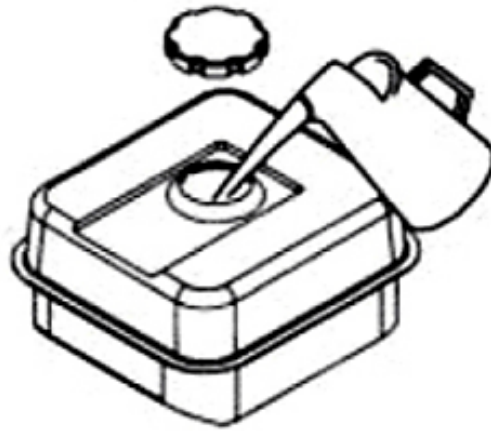

3.2.2 Compensate the fuel of fuel system

Unless there is air in the fuel system the fuel cannot be fed to the fuel injection pump.

This engine has an automatic bleeding system. Bleed air from the fuel system according to the following procedure:

1. Check the oil level in the fuel tank. Add the fuel if insufficient.
2. Open the cock of the fuel tank.
3. Turn the starting switch key to the ON position. The fuel feed pump operates to feed the fuel, and when the fuel filter is filled with fuel without any air space or bubbles, the engine is ready to be started.

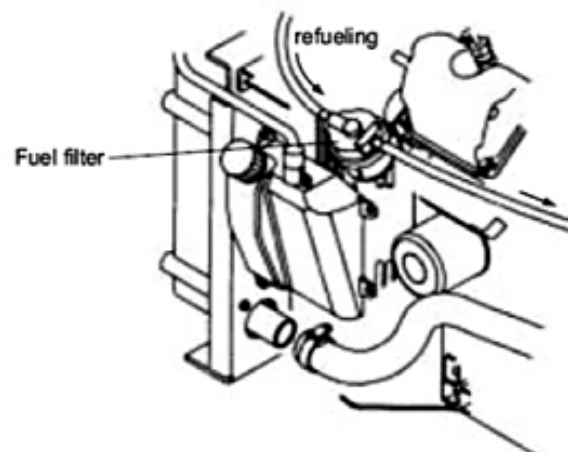

3.3 Supplying the Lube Oil

Supply the lube oil to the specified level as below:

1. Correct the engine position to become level.
2. Remove the yellow cap of the oil filler port on the side of the engine.
3. Check the oil level with the mark on the dipstick (level gauge). Oil should be filled to the upper limit on the dipstick.

Lube oil capacity: 2.3L

4. Tighten the oil dipstick.

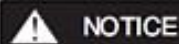
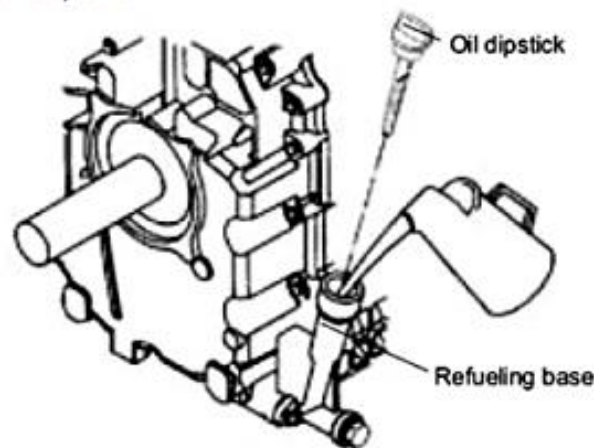

NOTICE

Do not screw the dipstick when checking the oil level.
Do not overfill the oil.

3.4 Supplying the Cooling Water

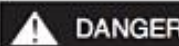

DANGER

Beware of burns from scalding

Never open the radiator cap while the engine is hot. Hot water or steam will spurt out to cause scalding. Wrap the radiator cap with a rag piece and slowly open after the radiator is cooled down.

After inspecting the cooling water capacity, securely tighten the radiator cap. If the cap is not secure, steam or hot water may spurt out during operation to cause scalding.

Supply the cooling water into the radiator and the sub-tank

1. Remove radiator cap.



When removing radiator cap;

Turn the cap counterclockwise by 90 degrees.

Push down the cap and turn it further counterclockwise to remove it.

Attempting to turn the cap without pushing it down may damage the cap.

2. Pour the cooling water gently into the filler port, taking care not to cause bubbling until it overflows.

Cooling water capacity: 2.6L

3. After supplying cooling water, surely tighten the radiator cap.

4. Check the cooling water rubber hose for disconnection of joint, loose connection, damage and other defective states. The cooling water may be consumed much, if the air-tightness is insufficient.

3.5 Cranking (No-load)

Perform (no-load) cranking before starting the engine for the first time or after a long-term storage, to circulate the lube oil sufficiently to each part. During a longterm storage, the lube oil can run out of the engine moving part. Operating the engine in such a state may cause seizure (sticking) of rotating parts.

1. Disengage all clutches and turn the starting switch OFF to eliminate any load.

2. Set the control lever (accelerator facilities) at LOW.

3. Put the key into the starting switch, turn the key to START and hold it there. The engine will be cranked.

4. Crank the engine for about 5 seconds by keeping the switch at START to observe abnormal sound.
5. Return the key to the OFF position to stop the engine.

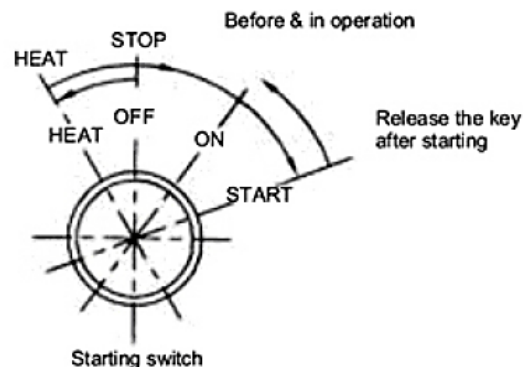

3.6 Checking the Lube Oil and Cooling Water

When lube oil or cooling water is supplied for the first time or replaced, run the engine for a while and check the oil and water levels again. Trial run makes the oil circulate through each part and the apparent level goes down. Refill oil to the specified level.

4. OPERATION

NOTICE This section describes the procedures for starting, adjusting the speed and stopping the engine and the preparation before keeping the engine in storage for a long time.

WARNING Never drink alcohol before operation

Never operate the engine while you are under the influence of alcohol or when you are ill or feel unwell as it results in unexpected accidents.

WARNING Exhaust gas poisoning

Do not block the ventilators, ventilation windows and holes, Provide good ventilation while the engine is running. Exhaust gas can be very toxic.



- Avoid operation in a closed room, tunnel, manhole, underground or in a ship's hold. Exhaust gas cannot get out.

Keep away from rotating parts

- Keep your hands, body and clothes sufficiently away from the rotating parts, cooling fan, V-belt, pulley, etc. during operation. Serious injury will result if trapped by these rotating parts.
- Do not operate the machine when any of its protective covers is removed.
- Check before starting the engine to see that no tools or clothes used in maintenance remains.

CAUTION Beware of scalding from contact with hot engine parts

Be careful not to touch the radiator, silencer, exhaust manifold, cylinder block and cylinder head during operation or immediately after stopping. Never touch these parts with your body or clothing. Otherwise, scalding will result.

4.1 Check Before Daily Operation

Be sure to check the following points before starting the engine every day.

1. Visual check around engine

Particularly check the following points:

If any abnormality is found, do not continue operation until it is corrected.

- Oil leak from the lubrication system
- Fuel leak from the fuel system
- Water leak from the cooling system
- Damaged parts
- Loosening or loss of bolts

2. Checking and adding fuel oil

Check the remaining fuel oil level in the fuel tank and add the



recommended fuel if necessary.

3. Checking and adding lube oil

- (1) Check the lube oil level with the oil dipstick.
- (2) If the remaining lube oil level is low, add the specified type of oil to the specified level through the filler port. Fill the oil to the upper limit mark while checking the level with the gauge.

4. Checking and adding cooling water

 **DANGER** Beware of scalding by hot steam

- Never open the radiator cap while the engine is hot. Hot steam or water splashes out to cause scalding.
- Wrap the cap with a rag piece and slowly open after the radiator is cooled down. Securely fasten the radiator cap after checking. If the cap is not secure, steam or hot water may spurt out to cause scalding.

Daily cooling water level check and addition shall be done only at the sub-tank. If the cooling water is below the lower limit in the sub-tank, check the cooling water level in the radiator.

Check the cooling water level while the engine is cool.

Check when the engine is hot is dangerous. And the water volume is expanded due to the heat.

Check the cooling water level in the sub tank. If the water level is close to the lower limit, open the sub-tank cap and add fresh water to the upper limit.

If the sub-tank water level is lower than the lower limit, open the radiator cap and check the cooling water level in the radiator. Add fresh water if the level is low.

 **NOTICE**

If the cooling water runs short quickly or when the radiator runs short of water with the sub-tank level unchanged, water may be leaking or the airtightness may be lost. In such cases, promptly consult with your

dealer. Increase in the sub-tank water level during operation is not abnormal. The increased water in the sub-tank returns to the radiator when the engine is cooled down.

5. Checking alarm operation

Before and after starting the engine, check to see the warning devices such as alarm lamps function normally. Failure of alarm cannot warn the lack of oil or water which results in trouble. Make it a rule to check the alarm operation before and after starting engine every day.

6. Checking reserve fuel, lube oil and cooling water

Provide the amount of fuel sufficient for daily operation. Also, prepare reserve lube oil and cooling water (at least the amount enough for full replenishment) near the operation area in preparation for an emergency.

4.2 Starting

4.2.1 Normal starting procedure

Start the engine as shown below.

1. Release all clutches and turn the starting switch to OFF to cut off the driven machine load.

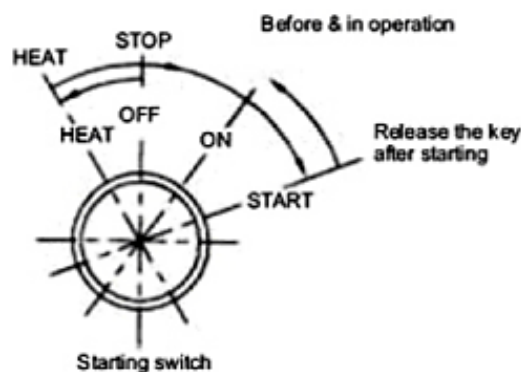

2. Open the cock of the fuel tank.
3. Turn the battery switch on.
4. Insert the key into the starting switch.



5. Turn the key from OFF to the ON position. Check all alarms are normal.
6. Set the accelerator (control lever) at the LOW position.
7. Turn the key to the START position to start the engine. When the engine starts, release the key. The key automatically returns to the ON position.

One starting switch operation should not exceed 15 Seconds. Any longer attempt will overheat the starting motor.

4.2.2 Starting at low ambient temperature

If the engine is hard to start in cold weather (approx. 0 or below), use the glow plug for easier starting.

Follow steps to of the above procedure, and then follow the steps below.

8. Turn the key from the OFF to the HEAT and stay there for approx. 15 seconds until the glow plug is heated up.
9. Turn the key to the START position. After the engine starts, release the key. The key returns to the "ON" position automatically.

 Limit the activation of the glow plug within 20 seconds for attempt. Lengthy operation damages the plug.

4.2.3 Restarting After Failure

To restart after a failure at the first attempt, wait for about 30 seconds. Then turn the starter switch key to START. If the engine cannot be started by several attempts, follow the steps in Section 6 Troubleshooting.

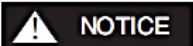

- Do not turn the starting switch key to the START position when the engine is not completely stopped or during operation. Otherwise, the starter gear train will be damaged.
- Wait at least 30 seconds before the second attempt to allow for

battery voltage recovery.

4.2.4 Check and Operation After Starting

1. After the engine starts, run it at a low speed and check the following points :

- Alarm lamps and instruments
- Water, oil and gas leak from engine
- Color of exhaust gas
- Vibration or noise

 **WARNING** High speed operation or abrupt loading without warming up may result in engine seizure.

2. If the engine is normal, run the engine at a low speed without any load for about 5 minutes. (This warms up the engine and allows circulation of the oil throughout the engine.)

4.3 Adjusting the speed

Raise the engine speed up to the rated speed by operating the accelerator lever (control lever).

 **NOTICE** Do not try abrupt acceleration or overload for the first 50 hours for a new engine.

4.4 Precautions During Operation

Watch the following points to check the engine conditions.

- Exhaust gas color

Avoid engine operation if black smoke continues to come out. Black smoke is generated when the engine is overloaded or engine is failed. This shortens the engine life.

- Abnormal noise or vibration

Depending on the driven machine structure, resonance may arise at a certain engine speed, resulting in sudden violent vibration. Avoid engine operation near that speed.

- Warning lamps

If an alarm lamp comes on, do not be flurried but decrease the engine speed and disconnect the driven machine load. Then, stop the engine, check the cause and take the necessary action.

- Water, oil or gas leakage, or loosened bolts

Occasionally check the engine and its peripheral parts for any symptom of leakage or loosened bolt.

- Low fuel level in tank

Always add fuel before the level drops too low during operation.

⚠ NOTICE Never switch off the battery or make a short circuit on the battery cable during operation. An abnormal surge can cause malfunctioning of the electrical system.

4.5 Stopping the engine

To stop the engine, take the following steps.

1. Remove the driven machine load by disengaging the clutch or turning the starting switch off.
2. Set the accelerator (control lever) to the LOW speed position and carry out cool-down operation for about 5 minutes.
3. Set the starting switch key to OFF to stop the engine.

Extract the key and store it at a safe place.

4. Turn off the battery switch.
5. Close the cock of the fuel tank.

If the engine fails to be stopped by setting the starting switch to OFF, close the cock of the fuel tank. The engine will soon stop as the fuel runs out.

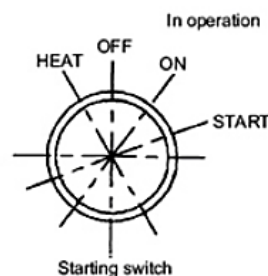

4.6 Taking care During Long-term Storage

When the engine is to be stored for a long time, take the following care.

4.6.1 Inspection and maintenance during long-term storage

1. Periodic check

If the next periodic check is drawing near, carry out the inspection before storage.

2. Draining of cooling water

If no antifreeze is added to the cooling water, be sure to drain the water from the inside of the engine.

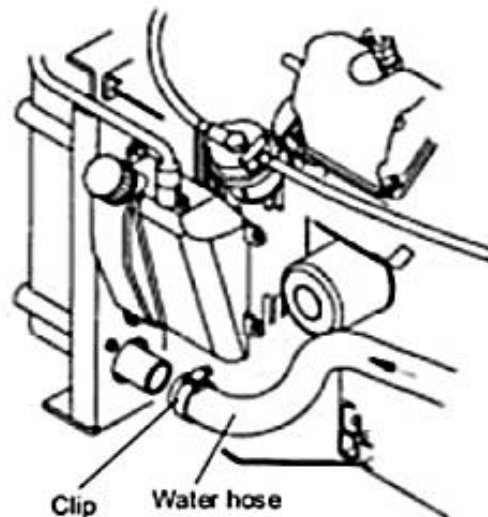

Precautions at draining hot water to prevent scalding Wait until the temperature goes down before draining cooling water. Hot water may splash to cause scalding.

- 1) Remove the radiator cap.
- 2) Loosen the clamp at the lower part of the cooling water hose and disconnect the hose. Cooling water will be drained.
- 3) After fully draining water, reconnect the cooling water hose and tighten the radiator cap.

 **NOTICE** If draining is neglected, the water remaining in the system in cold weather is frozen to damage the cooling water system components (radiator, cylinder block, cylinder head, etc.)

3. Exterior cleaning, fuel draining, and filling

- Clean dirt and oil off from the engine exterior wall.
- Thoroughly drain fuel or completely fill the fuel tank for preventing condensation.

4. Water-and dust-proofing

- Protect the air cleaner, silencer and electrical parts (alternator, starter, switch) from water and dust with airtight plastic covers.
- Store the engine at a well ventilated place not subject to high moisture or dust.

5. Measure against battery self-discharging

- Turn the battery switch off or disconnect the ground lead (-) of the battery.
- Recharge the battery monthly to compensate for the self-discharging.

4.6.2 Pre-operation check after long storage

For operation after long storage, make the same preparations as for the initial operation. Refer to Section 3 Before Operation.

5. MAINTENANCE

5.1 Checking

Periodic check:

The engine performance may deteriorate to the operation conditions and period of operation. Negligence of deteriorated functions and performance causes unexpected malfunctioning that may interrupt your work, increase fuel and lube oil consumption or increase exhaust gas and noise, resulting in shortening the engine life. Daily and periodic



checks and maintenance will maintain the engine efficiency and prevent malfunctioning.

Check before daily operation :

Daily check begins before operation. Make it a rule to carry out check before starting daily operation as given in section 4.1.

Periodic check intervals :

It is recommended to prepare an operation log to record daily operation and check results. When operating hours are or hour-meter reading is near the specified value, conduct periodic check as instructed herein.

The periodic check should be made at 50,200,400,1000 and 2000 operating hours.

Use CHANGCHAI Genuine Parts :

Be sure to use CHANGCHAI genuine parts for replacement of engine parts. Use of other parts will reduce engine performance and shorten the life of the engine.

Always have service tools on hand :

Keep service tools close to the machinery and ready for use in inspection.

Tightening torque of bolts and nuts :

Tighten nuts and bolts to the appropriate torques.

Over-tightening may damage the thread ,and under-tightening may cause oil leak from mating 27

surface or mechanical problems by loosened bolts.

Use a torque wrench for important parts and tighten the bolts to the correct torques in the specified order.

For maintenance requiring removal of parts, consult with your dealer or CHANGCHAI distributor.

The table below lists the standard tightening torques.

- Tightening torques listed below are applied to GB/T3098.1 8.8 class bolts only.
- For other bolts without the mark, use 60% of the listed torques.
- For aluminum alloy bolts, employ 80% of the listed torques.

N.m (kgf-m)

Blot dia.xpitch mm	M6x1.0	M8x1.25	M10x1.5	M12x1.75	M14x1.5	M16x1.5
Tightening torque	9.8-11.8 (1.0-1.2)	2.5-28.4 (2.3-2.9)	44.1-53.9 (4.5-5.5)	78.4-98 (8.0-10)	127.5-147.1 (13-15)	215.7-235.4 (22-24)

5.2 Periodic Check Program

Daily and periodic checks and maintenance are essential for keeping the engine in good working condition. The table below summarizes check items and periodic check intervals. General guidelines are shown as the optimum check intervals varies from engine to engine according two years to their applications, load conditions, qualities of fuel and lube oil in use and other operating conditions. The check and maintenance procedures for each check item are explained in 5.3.

 **NOTICE** Establish a periodic check plan according to the operating conditions and make sure to conduct checks at specified intervals. Otherwise, malfunctioning may occur to shorten the engine life.

As special knowledge and skill are required for items marked with ●, consult with your dealer or CHANGCHAI distributor.

○ : Check ◉ : Replace ● Consult CHANGCHAI dealer or distributor

System	Check item	Daily check s	Periodic check intervals				
			50h	200h	400h	1000h	2000h
Fuel oil	Fuel tank oil level check and addition	○					
	Fuel leak from fuel tank	○					
	Draining from fuel tank		○				
	Fuel filter replacement				◉		
Lube oil	Lube oil level	○					
	Lube oil leak	○					
	Lube oil replacement		◉	◉			
	Lube oil filter element replacement		Initial	later			
Cooling water	Check & addition of cooling water	○					
	Radiator fin cleaning			○			
	Cooling water replacement				●		
	Cooling water path flushing & maintenance					●	
Rubber hoses	Fuel oil pipe & cooling water pipe replacement					●	
Operating system	Accelerator operation	○					
	Idling speed adjustment				●		
Intake system	Air cleaner element cleaning & replacement		○ Cleaning	◉			
Electrical parts	Alarm operation check	○					
	Battery electrolyte check & recharging		○				
Cylinder head	Intake and exhaust valve head clearance adjustment			● Initial	● later		
	Intake and exhaust valve seat lapping						●
	Injection valve pressure check & adjustment					●	
Fuel valve pump	Fuel injection timing check & adjustment					●	
	Fuel injection pump maintenance						●

5.3 Periodic Check Procedure

5.3.1 Check at initial 50 hours of operation

Lube oil replacement (initial replacement)

CAUTION Precautions for draining hot oil to prevent scalding. If draining oil from the engine while it is still hot, do not let the oil splash on you.

During initial operation of the engine, the oil is quickly contaminated due to the initial wear of internal parts. Lube oil filter should also be replaced when lube oil is replaced. It is easier and more effective to drain the engine lube oil while the engine is still warm (not hot) after stopping the engine.

Drain the lube oil

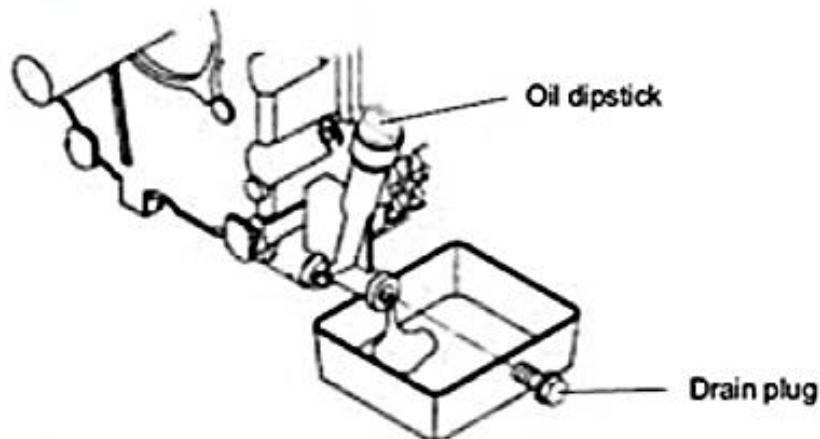

- 1) Prepare a waste oil container for collecting waste oil.
- 2) Loosen the drain plug under the oil filler port with a wrench to drain the oil.
- 3) After the oil is drained out, tighten the oil drain plug in case of loosen.

Replace the lube oil filter

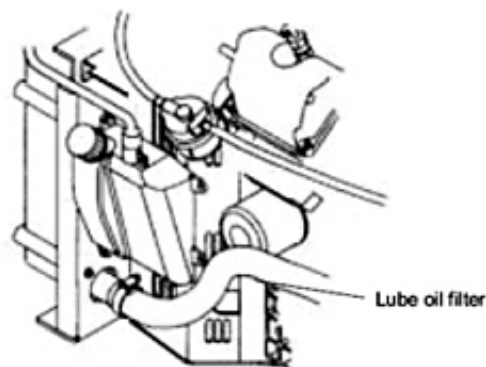

- 1) Turn the filter counterclockwise with a filter wrench to remove it.
- 2) Clean the filter mounting face.
- 3) Install the new filter by manually turning it clockwise until it comes into contact with the mounting surface, and tighten it further to 3/4 of a turn with the filter wrench.

Tightening torque: 19.6 ~23.5N m (2.0~ 2.4kgf-m)

Fill with new lube oil.

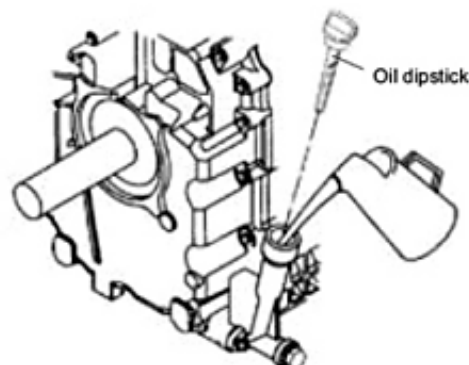

- 1) Fill with the specified amount of fresh lube oil as explained in section 3.3.

Lube oil capacity: 2.3L

- 2) Warm the engine up by running it for approx. 5 minutes while checking oil leakage.
- 3) Remove the lid from the oil filler port about 10 minutes after stopping the engine, check the oil level using the gauge and add oil as described

in section 3.6.

After initial use, replace the oil periodically at intervals of 200 hours.

5.3.2 Check every 50 hours of operation

1. Draining the fuel tank

Prepare a waste oil container to collect drainage.

Loosen the drain plug under the fuel tank to drain impurities such as water and dirt.

When the fuel is free from impurities, close the drain plug.

2. Checking the battery

 **WARNING** Beware of fire caused by electrical short circuit

- Always turn the battery switch off or disconnect the ground cable (—) before inspecting the electric system. Careless short circuit may cause a fire.

Beware of ventilation around the battery

- Well ventilate the area around the battery and keep fire sources away. Hydrogen gas generated during operation or charging may be ignited to start a fire.

Beware of battery electrolyte

- Be careful so as not to bring your skin or eye in contact with the battery electrolyte, which is a strong acid and can affect your skin or eye. Wash it off immediately with a large amount of fresh water if you get any on you.

- Check the battery electrolyte level.

If the battery electrolyte level is near the lower limit, refill to the upper limit. Insufficient level causes the battery life to be shortened and overheating leading to explosion.

The electrolyte level tends to drop more rapidly in the summer season. So, frequent check is needed, and distilled water is supplied.

- If the cranking is slower than the normal level to cause failure in

starting, recharge the battery. If the engine will not start even after charging, replace the battery.

3. Cleaning the air cleaner

⚠ CAUTION Beware of dirt from air blowing

Wear protective equipment such as goggles to protect your eyes when blowing compressed air. Dust or flying debris can hurt eyes.

The engine performance is adversely affected when the air cleaner element is clogged by dust. So, periodical cleaning after disassembly is needed.

When the engine is operated in a dusty location, clean the element more frequently.

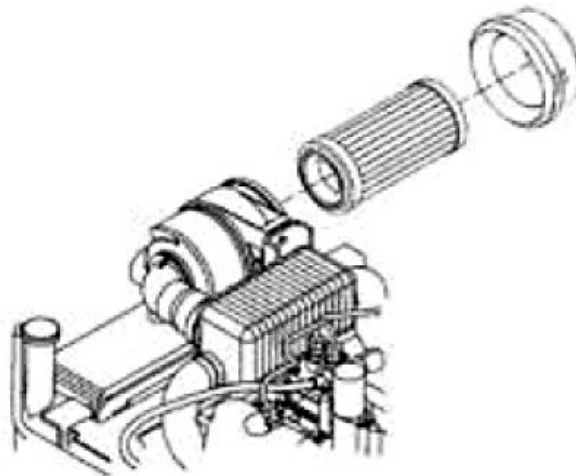

(1) Loosen 2 wing bolts on the top and remove the cover.

(2) Take out the element.

(3) Blow air from inside the element to blow dust off.

If the filter paper of the element is damaged, replace the element with a new one.

(4) Clean the inside of the case. Cover the suction port by a cloth to prevent foreign matters from falling into the intake manifold.

(5) Refit the element and put the cover on it, fasten the air cleaner with 2 wing bolts.

5.3.3 Check every 200 hours of operation

1. Replacing lube oil and lube oil filter (2nd time and after)

Replace the lube oil every 200 hours of operation from the second time and on.

Replace the lube oil filter at the same time. See section 5.3.1 1

2. Checking and cleaning radiator fins

CAUTION Beware of dirt from air blowing
Wear protective equipment such as goggles to protect your eyes when blowing compressed air. Dust or flying debris can hurt eyes.

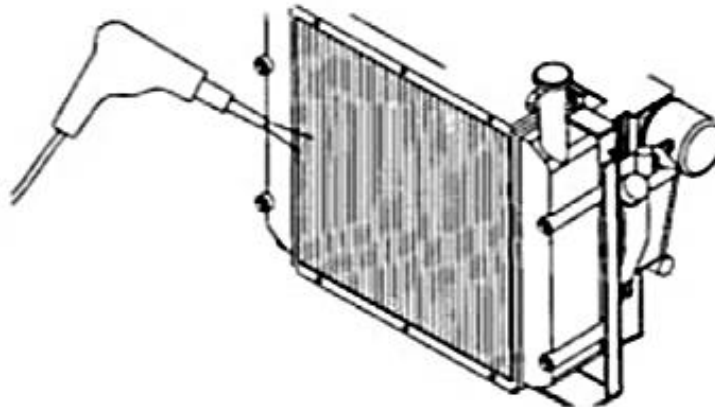

Dirt and dust adhering on radiator fins reduce the cooling performance, causing overheating. Make it a rule to check the radiator fins daily and clean as needed.

Blow off dirt and dust from fins and periphery with compressed air (196kPa 2kg/cm² or less).

If contaminated heavily, apply detergent, thoroughly clean and rinse with tap water shower.

NOTICE Never use high-pressure water or air from near the fins or attempt to clean with a brush. Radiator fins can be damaged.

3. Replacing air cleaner element

Damaged air cleaner element admits suspended matters in the open air into the combustion chamber to cause early engine wear and shortening of the engine service life. The air cleaner element significantly clogged with dust also reduces the engine output.

Replace the air cleaner element with a new one at regular intervals.

5.3.4 Check every 400 hours of operation

1. Replacing fuel filter

Replace the filter at regular intervals before it is clogged with dust to adversely affect the fuel flow.

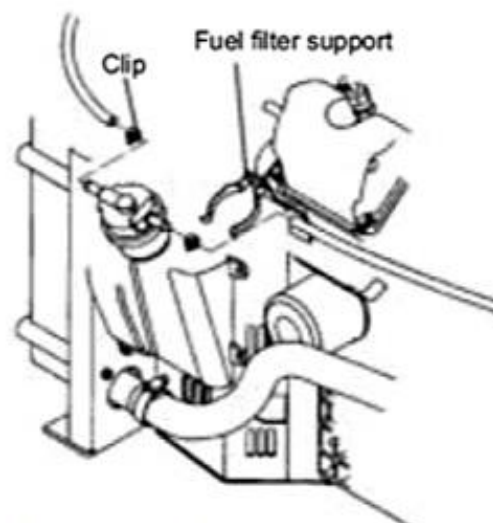

Close the cock of the fuel tank.

Loosen the hose clips on the fuel filter inlet and outlet joints to remove the fuel hose.

Draw out the element assembly and remove it from the support.

Press in a new fuel filter into the support until it is fixed in position.

Connect the hoses to the inlet and outlet joints. Fix them with hose clips.

After assembling, bleed air from the fuel system.

2. Replacing cooling water

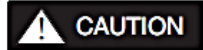

CAUTION Beware of scalding by hot water

Wait until the temperature goes down before draining the cooling water. Otherwise, hot water may splash to cause scalding.

Cooling water contaminated with rust or water scale reduces the cooling effect.

Even when antifreeze or anti-corrosive agent is mixed, the cooling water gets contaminated due to deteriorated ingredients. Replace the cooling water at least once a year.

3. Checking and adjusting intake/exhaust valve head clearance

As this adjustment requires special knowledge and skill, consult with your dealer or CHANGCHAI distributor. This adjustment is needed to correct deviated intake/exhaust valve open/close timing.

Negligence of this adjustment will cause noise generation from the engine and poorer engine performance.

4. Checking and adjusting fuel injector

As this adjustment requires special knowledge and skill, consult with your dealer or CHANGCHAI distributor. This adjustment is needed to obtain the optimum injection pattern for full engine performance.

5.3.5 Check every 1000 hours of operation

1. Cleaning the cooling system and checking cooling system parts

As this adjustment requires special knowledge and skill, consult with your dealer or CHANGCHAI distributor. Rust and water scale will accumulate in the cooling water system through 1000 hours of operation. This lowers the engine cooling effect and quickly deteriorates the cooling water. The following parts, especially, need cleaning and



maintenance each time the cooling water is replaced.

Cooling water system parts:

Radiator, cooling water pump, thermostat, cylinder blocks, cylinder heads, etc.

5.3.6 Check every 2000 hours of operation

1. Checking and replacing fuel hoses and cooling water hoses

As this adjustment requires special knowledge and skill, consult with your dealer or CHANGCHAI distributor. Regularly check the rubber hoses of the fuel system and cooling water system. If cracked or degraded, replace them with new ones.

2. Lapping intake and exhaust valves

As this adjustment requires special knowledge and skill, consult with your dealer or CHANGCHAI distributor. The valves must be lapped to maintain air-tightness of respective cylinders.

3. Checking and adjusting fuel injection timing

As this adjustment requires special knowledge and skill, consult with your dealer or CHANGCHAI distributor. The fuel injection timing must be adjusted for best engine performance.



6. TROUBLESHOOTING

In case of an abnormality, stop the engine immediately and locate a problem by referring to the following table.

SYMPTOM	PROBABLE	CAUSEACTION	Ref. Section
Warning lamps lighting during operation	NOTICE When a warning lamp lights, immediately stop the engine and check and remove the cause		
Lube oil Pressure lamp	Insufficient level of engine oil Clogged lube oil filter	Replenish engine oil. Replace the filter element.	3.3 5.3.1
Cooling water Temp. warning lamp	Low radiator cooling water level. Contaminated radiator fins. Leak of cooling water. Contaminated cooling water piping. Faulty cooling water pump.	Replenish cooling water. Clean the radiator. Repair the leaking parts. Clear or replace the cooling water piping. Call for service.	3.4 5.3.2 (2)
Charge lamp	Battery failure Faulty alternator	Recharge Check battery fluid Call for service	5.3.2 (2)
Faulty warning lamp	Notice If a warning lamp is faulty, do not continue operation. Otherwise, faults will not be noticed, developing a serious accident.		
Any of lamps not lighting when starter switch is turned ON	Faulty electrical wiring. Faulty lamp.	Correct the wiring. Replace the lamp.	
Any of lamps not lighting when starter switch is set from START to ON	Faulty sensor	Repair the switches.	
Failing to start			
self -starter running but the engine fails to start	No fuel . Air mixed in the fuel pipe. Incorrect fuel oil. Failure of ignition at low temp. Clogged fuel filter. Incorrect fuel injection timing. Clogged the injector nozzle. Compression leak from valves.	Replenish the fuel. Bleed air. Replace with correct oil. Use the glow plug. Replace the fuel filter. Call for repair. Call for repair. Call for repair.	3.2 3.2.2 3.1.1 4.2.2 5.3.4(1)



SYMPTOM	PROBABLE	CAUSEACTION	Ref. Section
Self –starter not running (hand turn possible) (hand turn not possible)	Low battery voltage. Poor contact of cable terminals. Faulty starter switch Faulty starter	Check battery fluid level. Clean terminal off rust and fasten. Replace the start switch. Call for repair.	5.3.2 (2)
	Faulty or burnt internal parts	Call for repair.	
Abnormal exhaust gas color			
Black smoke	Overloaded. Clogged air cleaner. Incorrect fuel. Abnormal fuel injection pattern. Large clearance of suction/exhaust valve heads.	Reduce the load. Replace or clean the element. Use the correct type of oil. Call for repair Call for repair.	5.3.2(3) 3.1.1
	Incorrect fuel. Abnormal fuel injection pattern. Lube oil burning. Abnormally large amount of lube oil consumption	Use the correct type of fuel. Call for repair. Call for repair. Call for repair.	3.1.1

TROUBLESHOOTING INFORMATION

If your engine is not working normally, check it referring to the troubleshooting section.

You can of course consult you CHANGCHAI dealer.

When asking the service, please give the following information to your CHANGCHAI dealer;

- Model name and serial number of your engine
- Engine type number
- Operating conditions. which speed or work has brought a problem.
- How long have you used your engine? (Approximate area worked or hours of operation)
- Situation when a trouble is developed
(engine revolution, color of exhaust gas, fuel in use, lube oil type, engine sound, etc.)
- History of troubles
- Any other information when a trouble has occurred.

DIAGRAMA ELECTRICO CONEXIÓN ECU

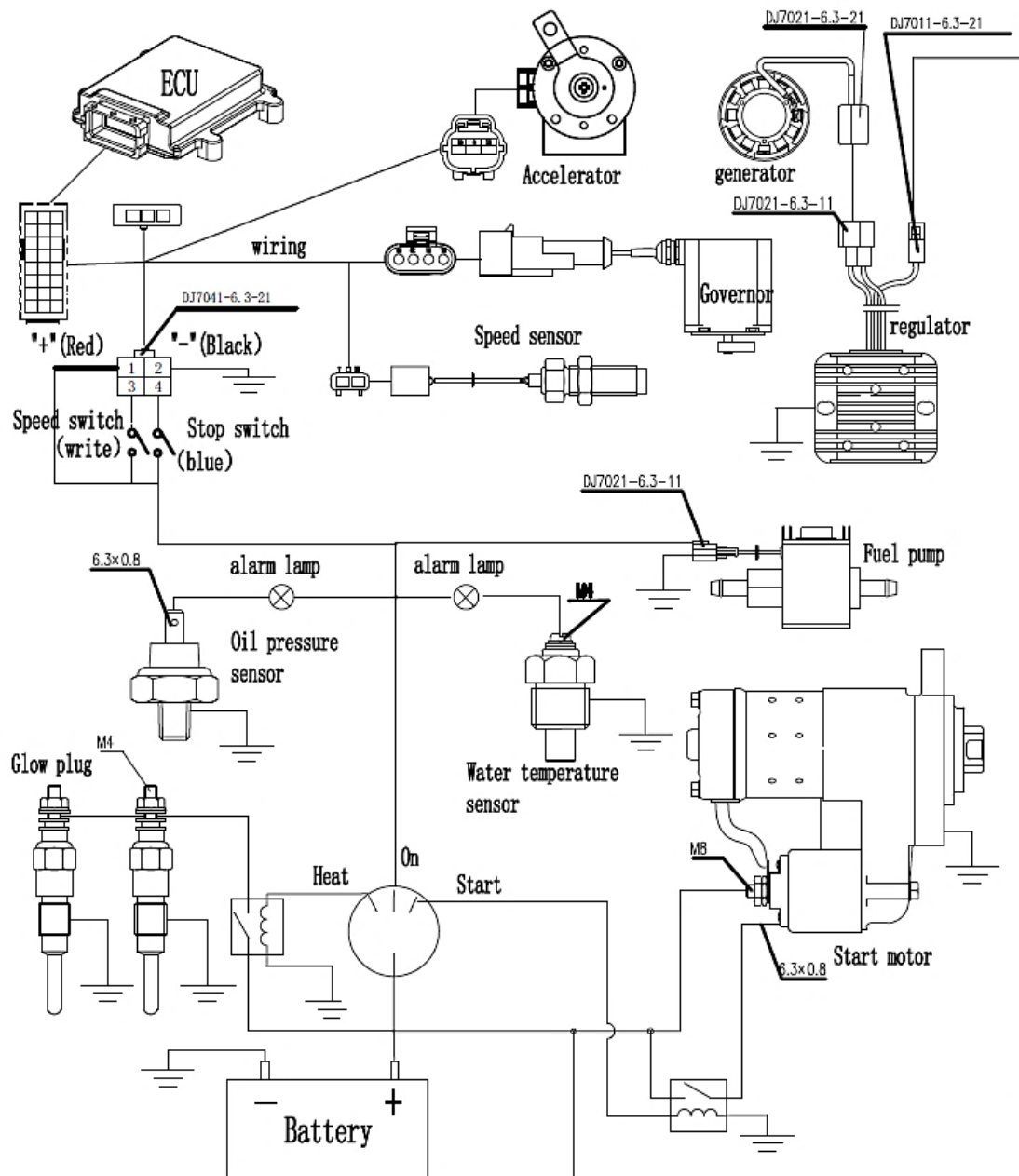

Instructivo Conexión Sistema Arranque:

1. Realizar la conexión en los bornes de los cables negativo (NEGRO 10mm²) y positivo (ROJO 100mm²) a los bornes de la batería.
2. Colocar el rectificador regulador de voltaje sujetando sobre el motor.
3. Verificar las conexiones del sistema eléctrico, de forma tal que todas estén en su lugar correspondiente (presión aceite, temperatura de agua, bomba combustible y conexiones ECU).
4. Colocar 1 litro de refrigerante total GLACELF SUPRA TIPO A colocar amarillo y completar hasta el nivel de operación con agua destilizada.
5. Colocar aceite al motor.
6. Realizar la conexión de la manguera de combustible a la bomba.
7. Conectar positivo y negativo de la batería a los cables del tablero según corresponda.
8. Antes de dar marcha, respetar el tiempo de calentamiento (15 seg.)
9. Luego de encendido y en marcha con el pulsador negro en el tablero es posible acelerar el motor de 1800 RPM a 3000 RPM.

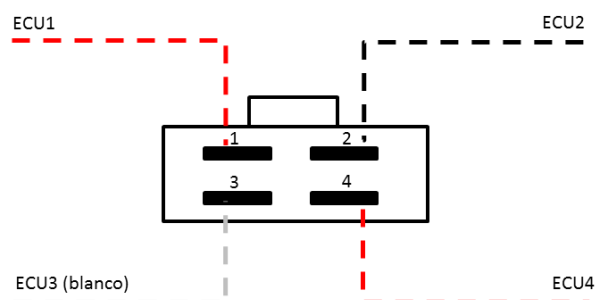
CONECTOR ECU**OPERATION MANUAL**



GARANTIA DE RESPALDO